

PRODUCT SUBMITTAL

WIRE-BOND

Flat Drip Edge(Drip Plate) Flush End

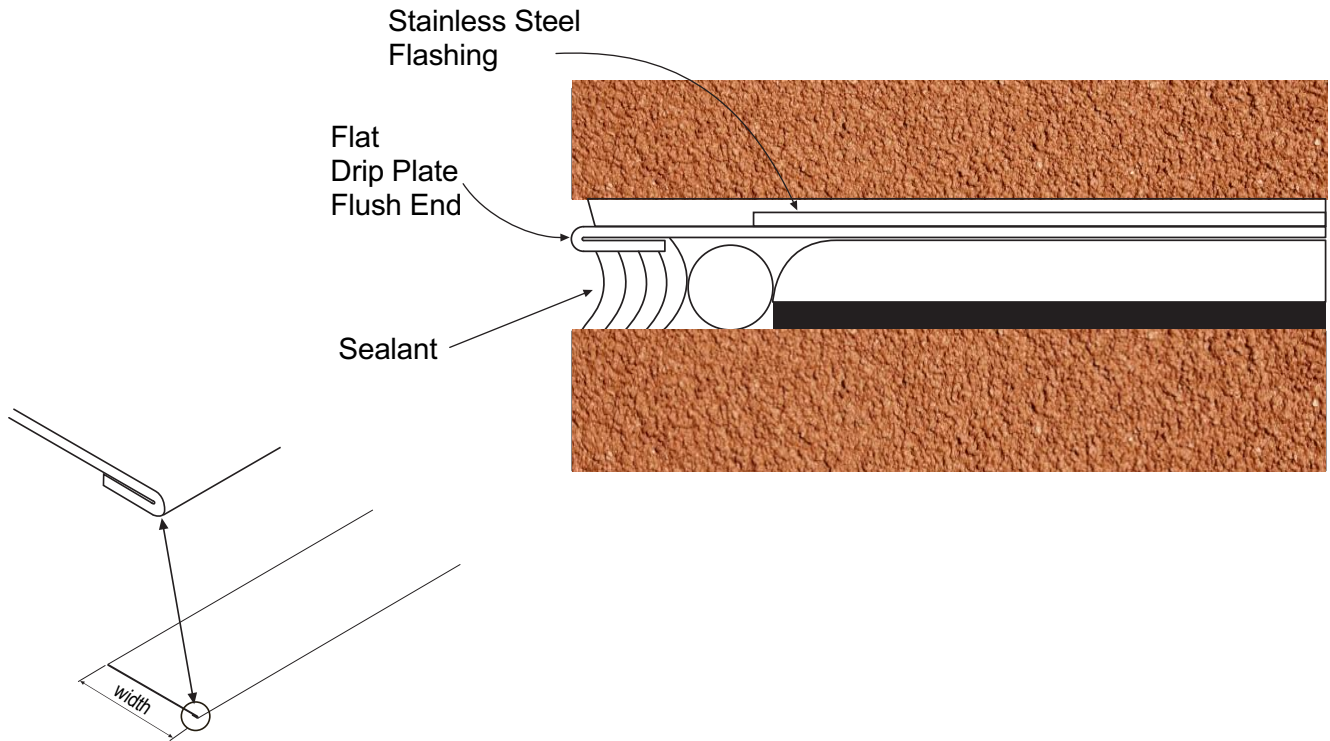

MATERIAL CONFORMANCE

Stainless Steel: Type 304 & 316

ASTM A240/A240M, ASTM A666
ASTM A480, ASTM A167

Copper:

ASTM B370 - #110 Alloy



Recycled Content:

Stainless Steel

97% Pre-Consumer V O C Content - 0%

SIZES / FINISHES

Flat Drip Plate:

Type 304 Stainless Steel 26 gauge standard

Type 316 Stainless Steel 26 gauge standard

Copper 16 ounce

Copper 12 ounce

Custom Gauge:

Type 304 Stainless Steel gauge

Type 316 Stainless Steel gauge

Optional:

Inside Corner

Outside Corner

End Dam

Width:

1 ½"

2"

2-½"

3"

3-½"

Other _____

Corporate Office: 400 Rountree Rd Charlotte, NC 28217
TEL: (800) 849-6722 FAX: (704) 525-

3761
Mailing Address: P.O. Box 240988 Charlotte, NC 28224



www.wirebond.com

Memphis Plant: 2365 Harbor Ave. Memphis, TN 38113
TEL: (800) 441-8359 FAX: (901) 775-9449

Mailing Address: P.O. Box 13124 Memphis, TN 38113